

REINHOLD ENVIRONMENTAL Ltd.



**2014 NO<sub>x</sub>-Combustion Round Table  
& Expo Presentations**

February 10 & 11, 2014, in Charlotte, NC / Hosted by Duke Energy

All presentations posted on this website are copyrighted by Reinhold Environmental, Ltd (RE). Any unauthorized downloading, attempts to modify or to incorporate into other presentations, link to other websites, or obtain copies for any other uses than the training of attendees to RE's Conferences is expressly prohibited, unless approved in writing by RE or the original presenter. RE does not assume any liability for the accuracy or contents of any materials contained in this library which were presented and/or created by persons who were not employees of RE.

# CFD and Physical Modeling of DSI Distribution

NO<sub>x</sub> Round Table

February 11, 2014

Matt Gentry

Airflow Sciences Corporation  
mgentry@airflowsciences.com  
734-525-0300



# Outline

- ❖ Introduction
- ❖ Flow Analysis Techniques
- ❖ Application to Air Pollution Control Equipment
- ❖ Sorbent Injection Modeling
- ❖ Conclusions

# Introduction

## ❖ Why is Fluid Flow Important to Industrial Equipment?

- Performance
  - Flow uniformity
  - Sorbent injection
  - Ash capture / build-up
- Operating costs
  - Pressure drop
  - Erosion
  - Corrosion
  - Sorbent Usage

## ❖ Applications

- Design of new equipment
- Retrofit of existing equipment
- Solving operational or maintenance issues

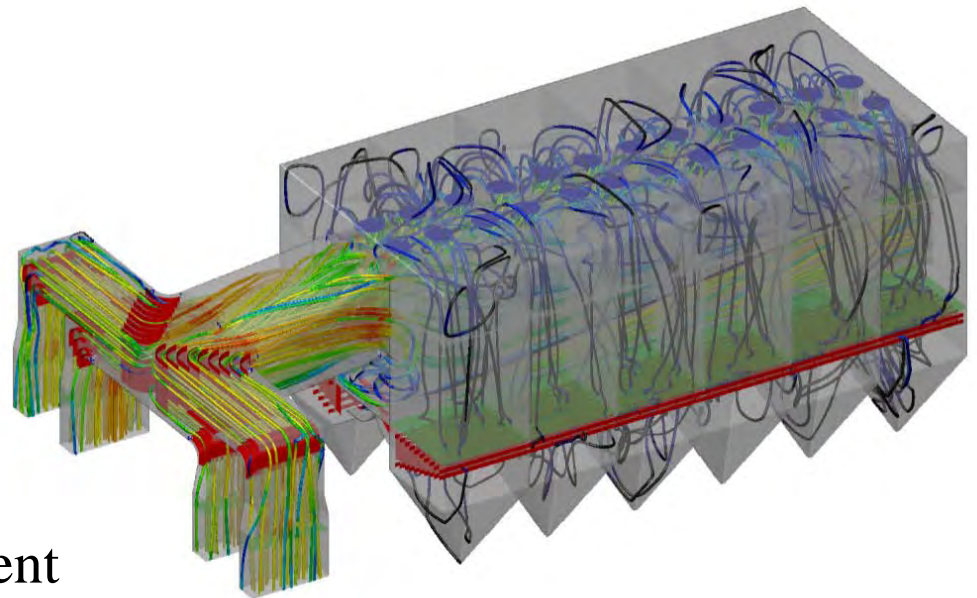

# Outline

- ❖ Introduction
- ❖ Flow Analysis Techniques
  - Computational Fluid Dynamics (CFD)
  - Physical Flow Modeling
- ❖ Application to Air Pollution Control Equipment
- ❖ Sorbent Injection Modelling
- ❖ Conclusions

# Computational Fluid Dynamics (CFD)

- ❖ Numerical simulation of flow
- ❖ Utilize high speed computers and sophisticated software
- ❖ Calculate flow properties
  - Velocity
  - Pressure
  - Temperature
  - Species
  - Particle streamlines

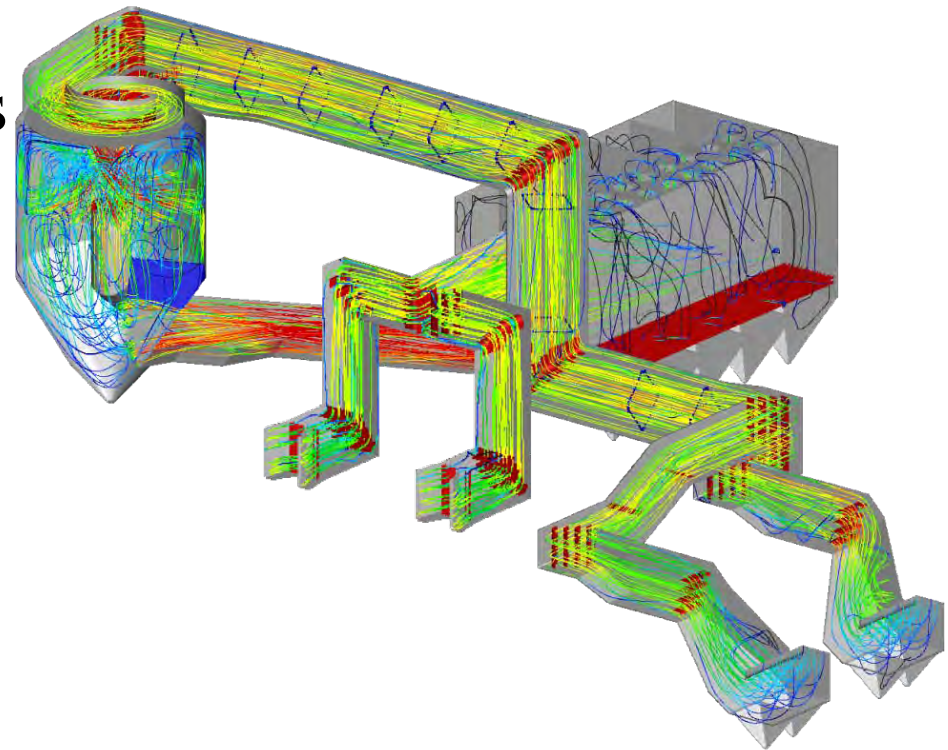

# Computational Fluid Dynamics (CFD)

## ❖ Control Volume Approach

- Divide the flow domain into distinct control volumes
- Solve the Navier-Stokes equations (Conservation of Mass, Momentum, Energy) in each control volume

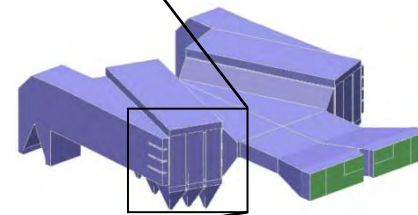
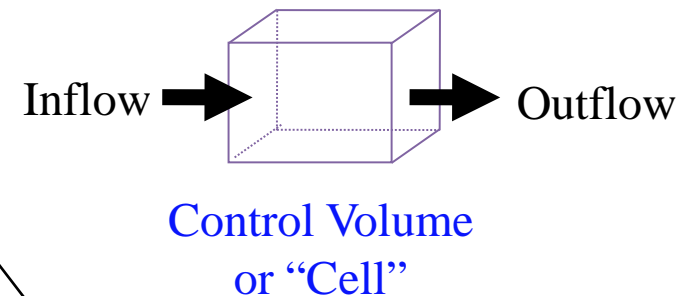
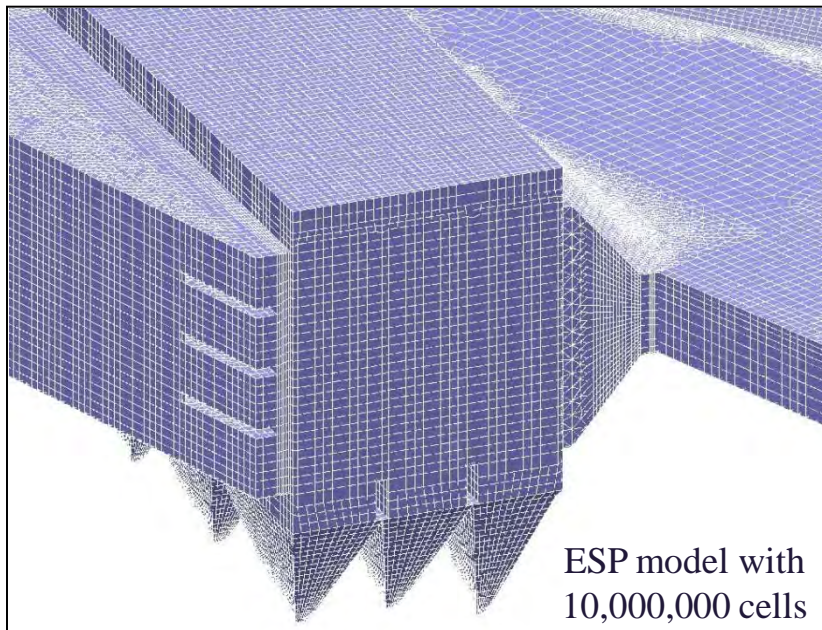

# Physical Flow Modeling

- ❖ Lab representation of geometry
- ❖ Typical scale 1:8 to 1:16
- ❖ “Cold flow” modeling
- ❖ Visualize flow with smoke
- ❖ Simulate ash deposition
- ❖ Measure flow properties
  - Velocity
  - Pressure
  - Tracer gas
  - Dust/Particles



# Physical Flow Modeling

Typical 1:12 scale  
physical model

SDAs

Air Heater Outlet

PJFF  
Compartments

Turning vanes

ID Fan Inlet



# Outline

- ❖ Introduction
- ❖ Flow Analysis Techniques
- ❖ Application to Air Pollution Control Equipment
  - Fabric Filter
  - SCR
  - Sorbent Injection
- ❖ Sorbent Injection Modelling Process
- ❖ Conclusions

# Fabric Filter Flow Modeling

- ❖ Uniform velocity distribution and equal balance between compartments
- ❖ Pressure loss
- ❖ Avoid bag erosion
- ❖ Ash deposition

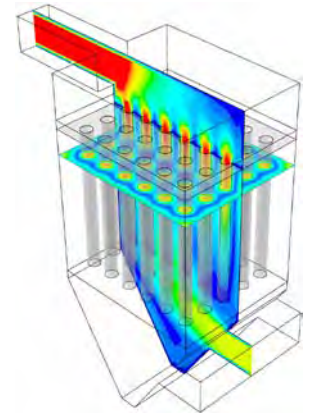
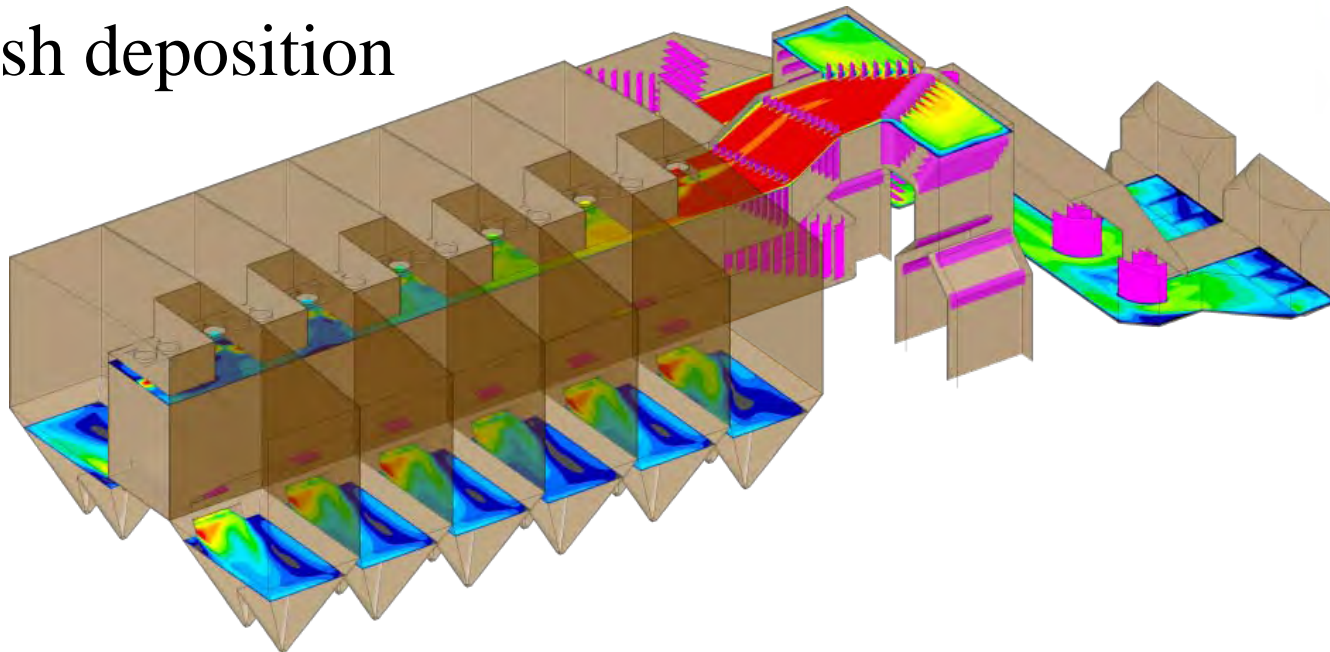

# SCR Flow Modeling

- ❖ Uniform velocity distribution
- ❖ Thermal mixing
- ❖ NO<sub>x</sub> profile and mixing
- ❖ Ammonia injection
- ❖ Pressure loss
- ❖ LPA capture
- ❖ Ash deposition

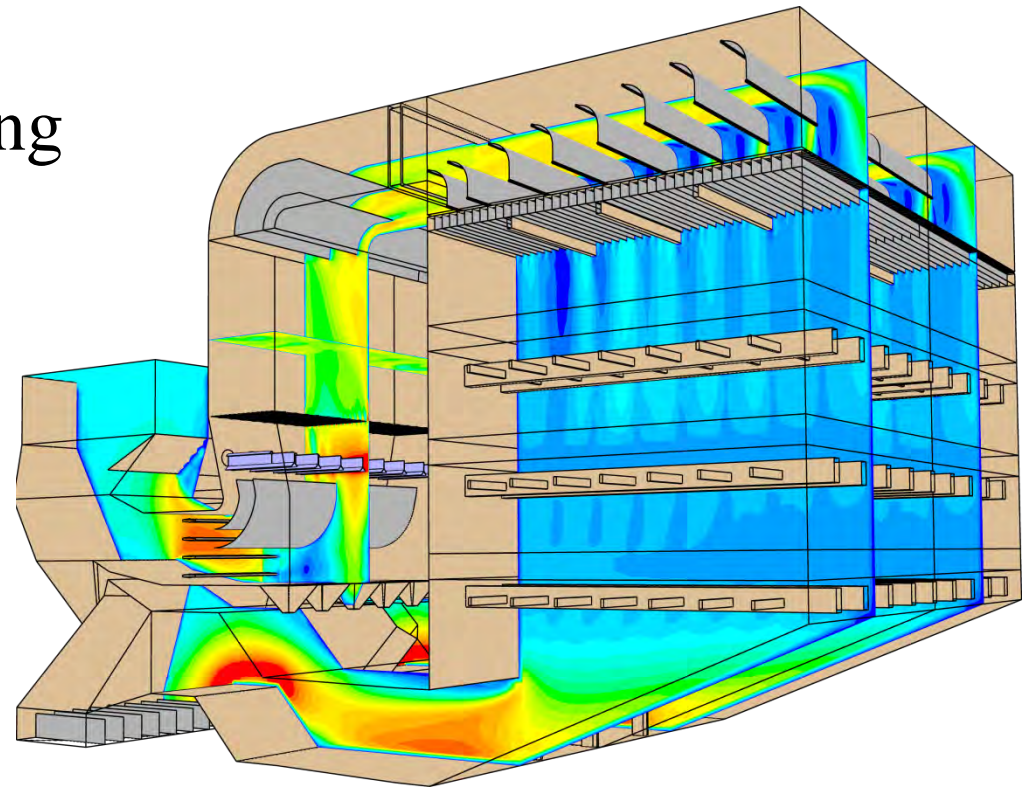

# Mercury / SO<sub>3</sub> Reduction

- ❖ Injection upstream of FF or ESP
  - Activated carbon
  - Lime, Trona, SBC, etc.
- ❖ Uniform injection
- ❖ Maximize residence time
- ❖ Maximize uniformity at FF/ESP

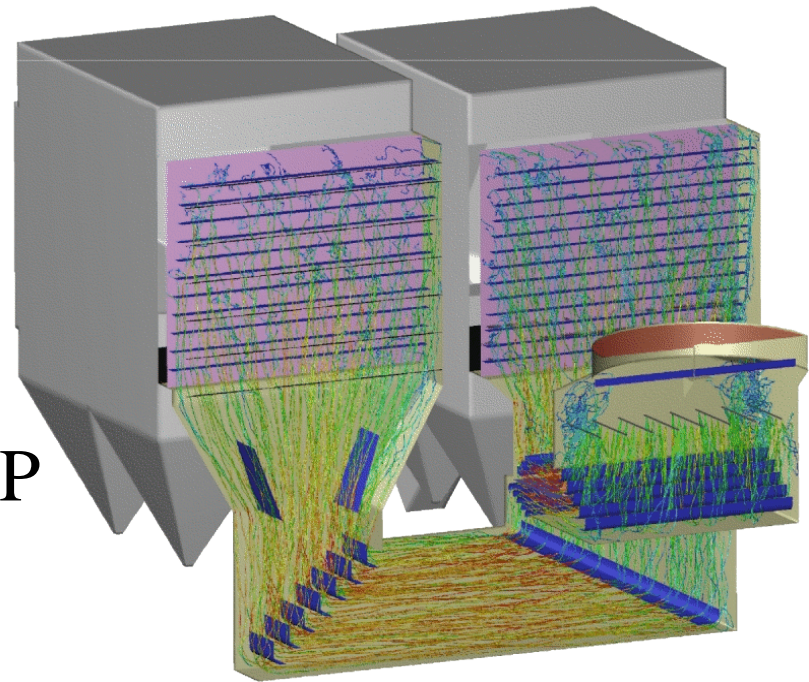

# Outline

- ❖ Introduction
- ❖ Flow Analysis Techniques
- ❖ Application to Air Pollution Control Equipment
- ❖ Sorbent Injection Modeling
  - Process
  - CFD Applications
  - Physical Modeling Applications
  - Comparison
  - Future Considerations
- ❖ Conclusions



# Sorbent Injection

- ❖ Several CFD techniques to analyze particulate behavior. The choice depends on factors including;
  - Particle loading
  - Particle size
  - Particle density
  - Turbulence
  - Gas velocity

# Sorbent Injection

## ❖ Modeling Techniques

- Lagrangian
  - Model particles directly
  - Forces on each particle calculated (aerodynamic drag, gravity, impacts, acceleration)
  - Commonly used for: flyash, LPA, erosion studies
- Eulerian
  - Model particles as a gas
  - Applicable for very small particles ( $<50\ \mu\text{m}$ )
  - Commonly used for: sorbent injection modeling
- Fully-Coupled Two-Phase
  - Combination of Eulerian and Lagrangian, where influence of the particles on the gas stream is accounted for
  - Solved iteratively with many, many particles tracked
  - Applicable for gas streams with very high particle loading or significant particle density
  - Commonly used for: coal flow in a pulverizer or coal pipe, fluidized bed

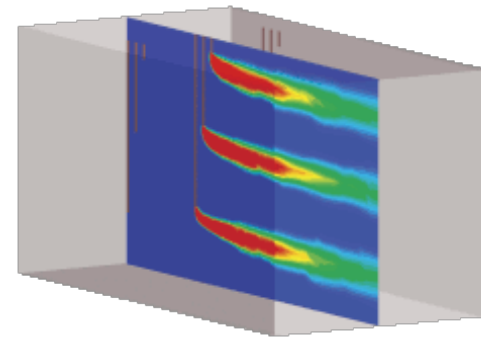
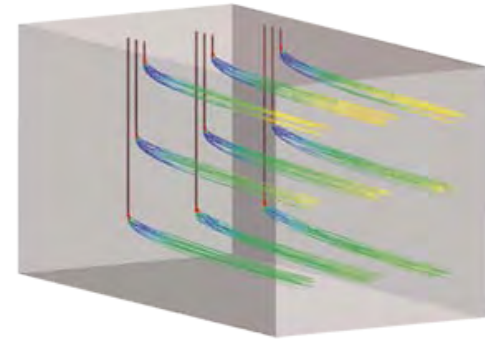

❖ Mesh geometry and quality is critical for each

# Sorbent Injection

- ❖ Eulerian vs Lagrangian for a typical power plant duct

Mass Fraction (Eulerian)

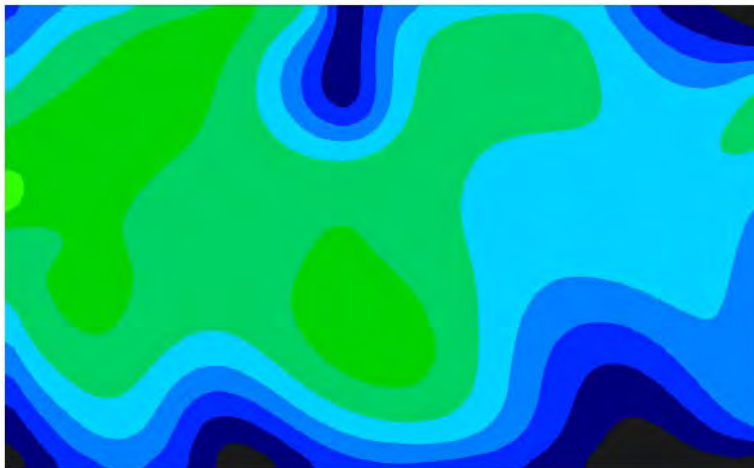

Particulate Tracking (Lagrangian)

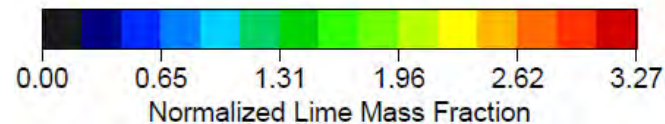
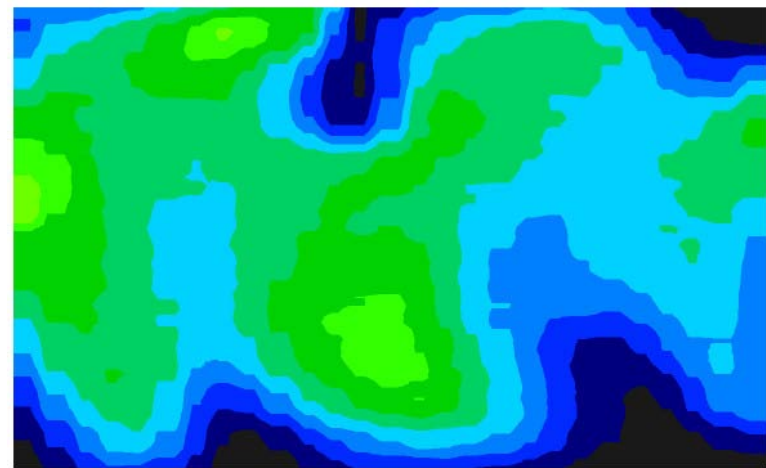

# Sorbent Injection

## ❖ Sorbent Injection Modeling: The Process

- Discuss the design parameters and restrictions regarding the injection lances (location, number of lance, etc.)
- Perform a baseline flow simulation with the initial injection grid geometry

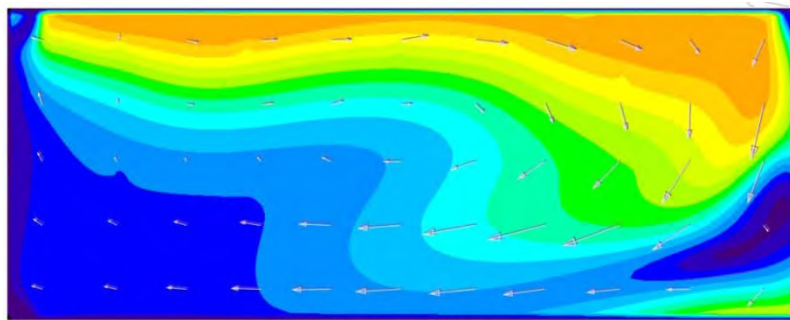

Average Velocity = 62.5 ft/s  
Streamwise Velocity RMS = 86.8%



0.0 30.0 60.0 90.0 120.0 150.0  
Total Velocity (ft/s)

Gas Velocity

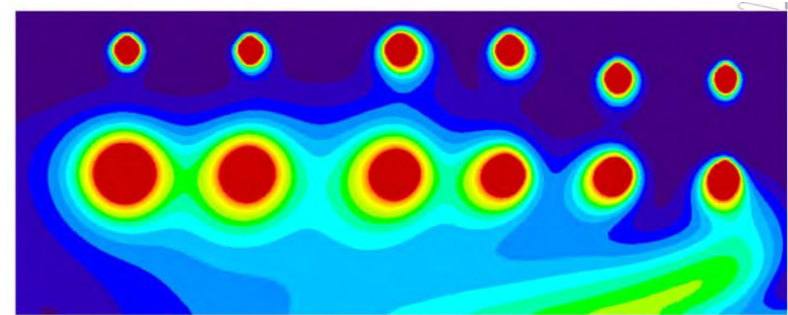

0.00 1.30 2.60 3.90 5.20 > 6.50  
pac (kg/kg-total) x 10<sup>-5</sup>

PAC Injection Concentration

# Sorbent Injection

## ❖ Sorbent Injection Modeling: The Process

- Issue a report with details of the flow and sorbent distribution throughout the model domain

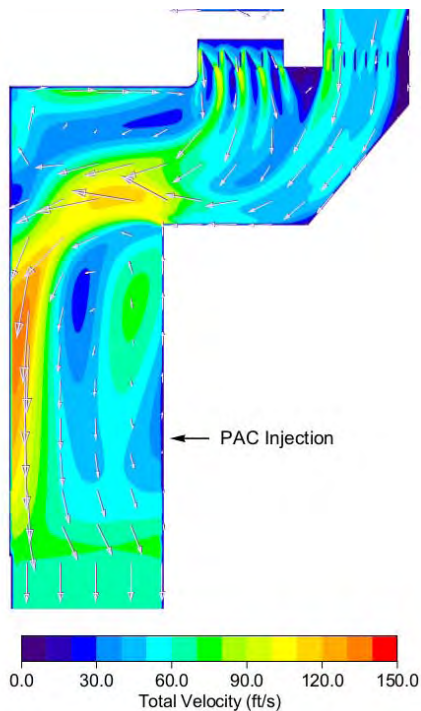

Gas Velocity

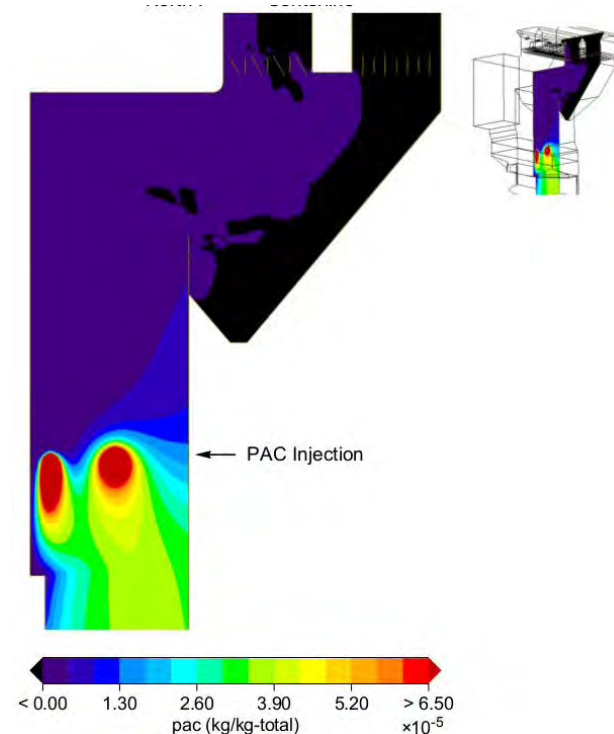

PAC Injection Concentration

# Sorbent Injection

## ❖ Sorbent Injection Modeling: The Process

- Particle residence time and sorbent uniformity at the target planes are presented

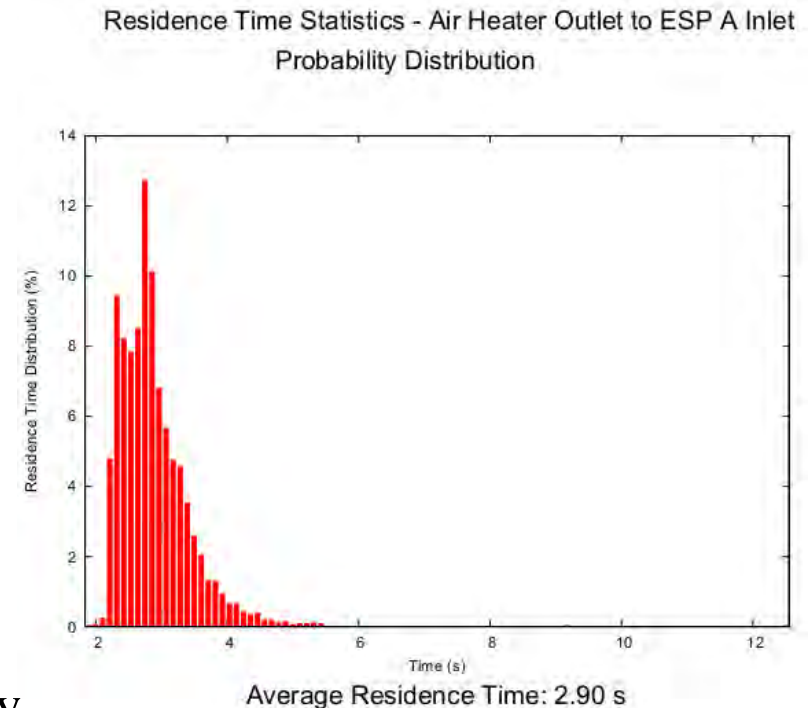
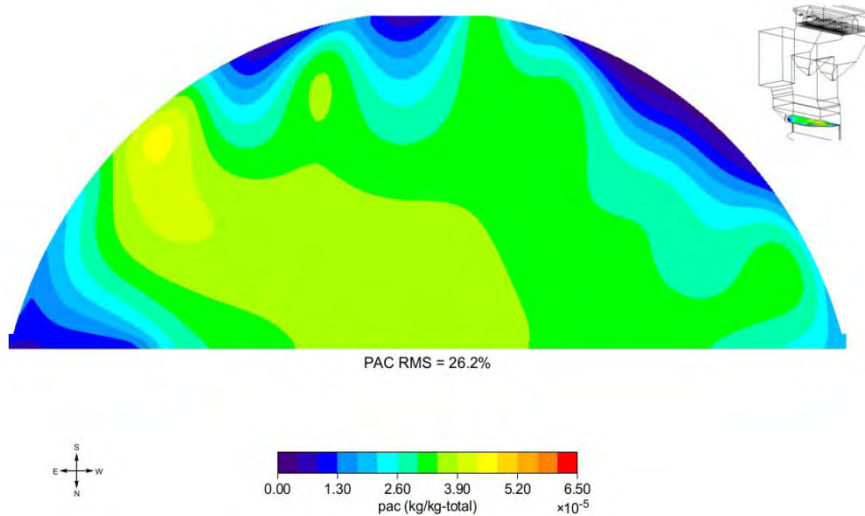

15-20% is the industry standard for uniformity

# CFD Applications

## ❖ Example 1: Trona and Carbon Injection

Unit 1 - Design 2 - Mass Fraction of Carbon

Isometric View

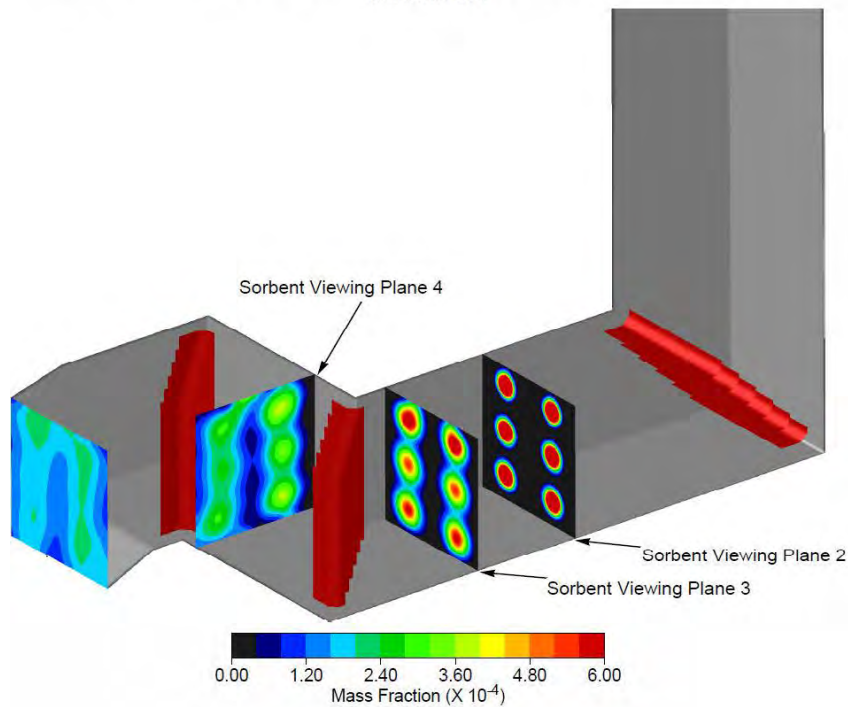

Unit 1 - Design 2 - Mass Fraction of Trona

Isometric View

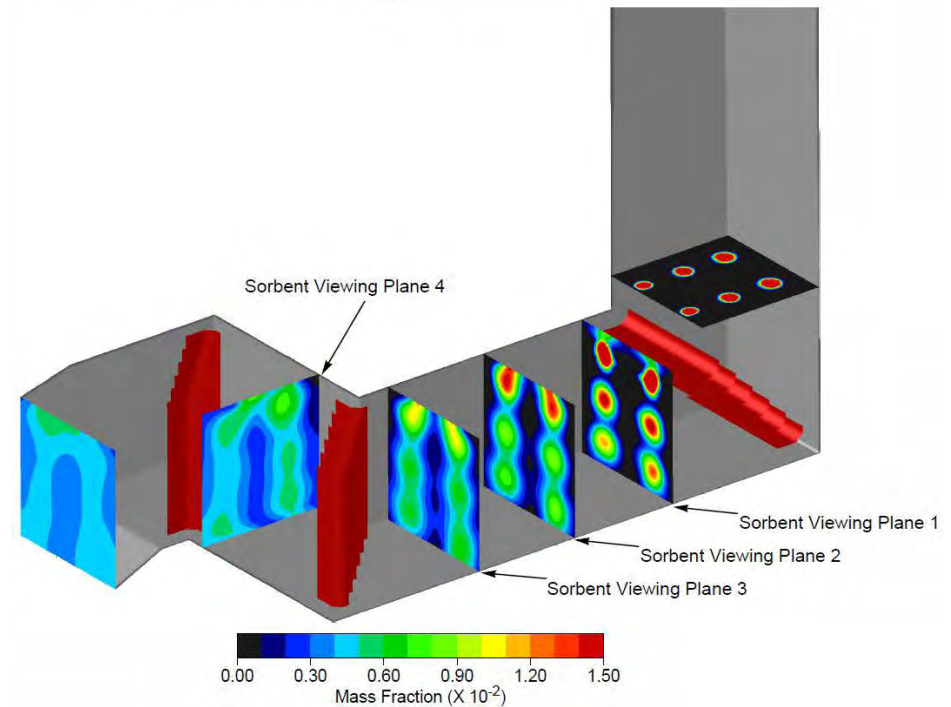

# CFD Applications

## ❖ Example 2: Carbon Injection with Multiple Air Heaters

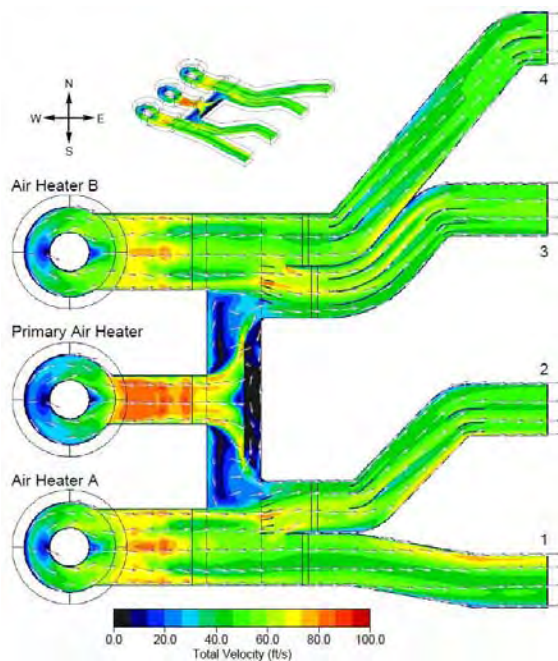

Gas Velocity

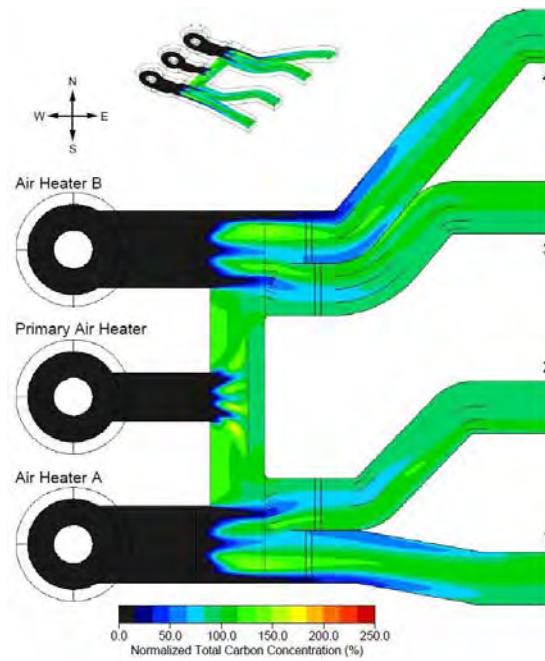

PAC Injection Concentration

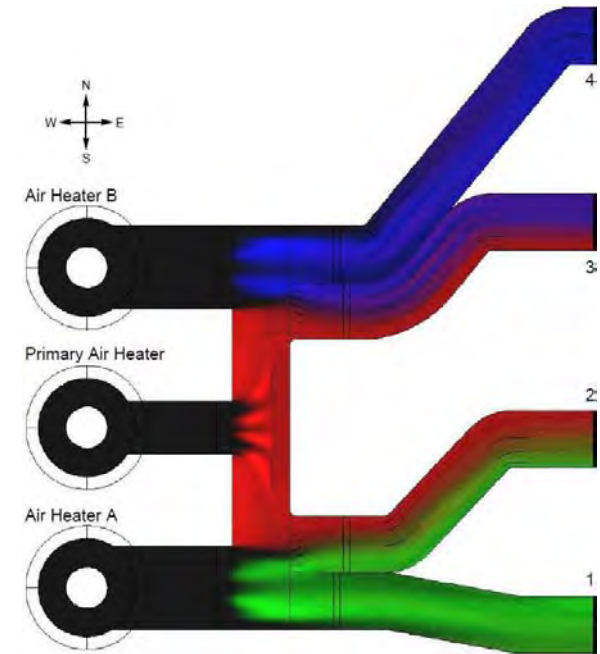

PAC Injection Balance

# Physical Flow Modeling Applications



# Physical Flow Modeling Applications

- ❖ Lab representation of lance geometry
- ❖ Sorbent injection modeled using tracer gas
- ❖ Gas analyzer used to measure distribution downstream



# Modeling Comparison: CFD/Physical

Target	CFD	Physical
DSI Uniformity – Target Plane 1	6.9%	3.9%
DSI Uniformity – Target Plane 2	9.1%	7.5%
ACI Uniformity – Target Plane 1	11.4%	12.7%

- ❖ Example data comparison from recent projects
  - Data comparable between the two methods
  - Tracer gas testing for other applications (NO<sub>x</sub> distribution, NH<sub>3</sub> injection) confirms good agreement

# Modeling Comparison: CFD/Physical

CFD	Physical
\$	\$\$
Multiple configurations investigated simultaneously	One test at a time
Can include lance details	Lance does not scale (2" dia lance not modeled as 1/6" dia lance)
More data points	Discrete data grid for analyzing mixing
Assumptions related to meshing or algorithm	Assumptions related to scaling and similarity

# Future Considerations

## ❖ Typical Parameters to Consider:

- Do you have enough lances?
- Residence time compared to duct size.
- Is your lance configuration well-suited for the duct aspect ratio?
- Can the plant fans handle dp of a static mixer?
- Substantial internal trusswork?
- You don't necessarily want the most uniform velocity profile at the injection plane.

# Future Considerations

## ❖ Do you have enough lances?

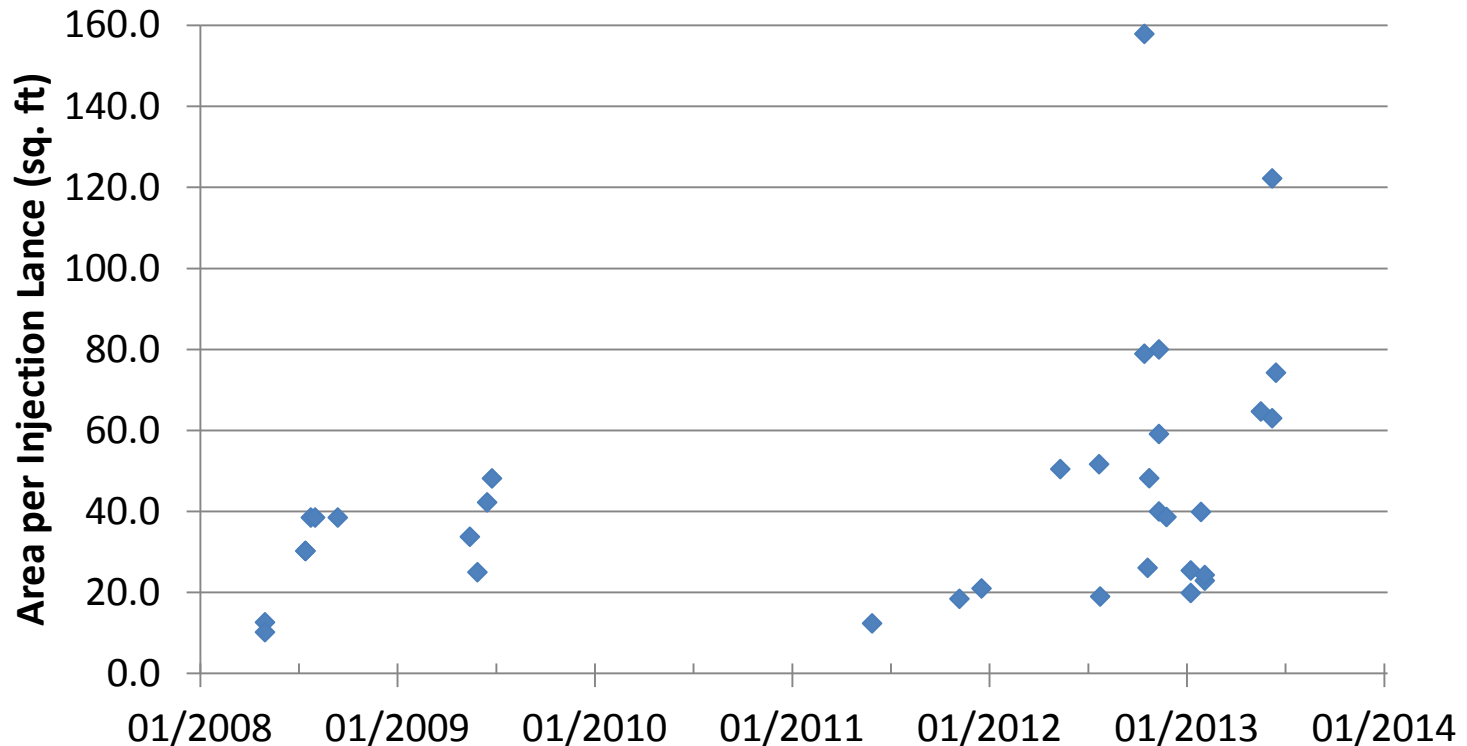

- ❖ 40-45 square feet per lance is a good guideline.
- ❖ Adding more lances after contract award is a tough pill to swallow.

# Future Considerations

## ❖ More Lances = Better Uniformity

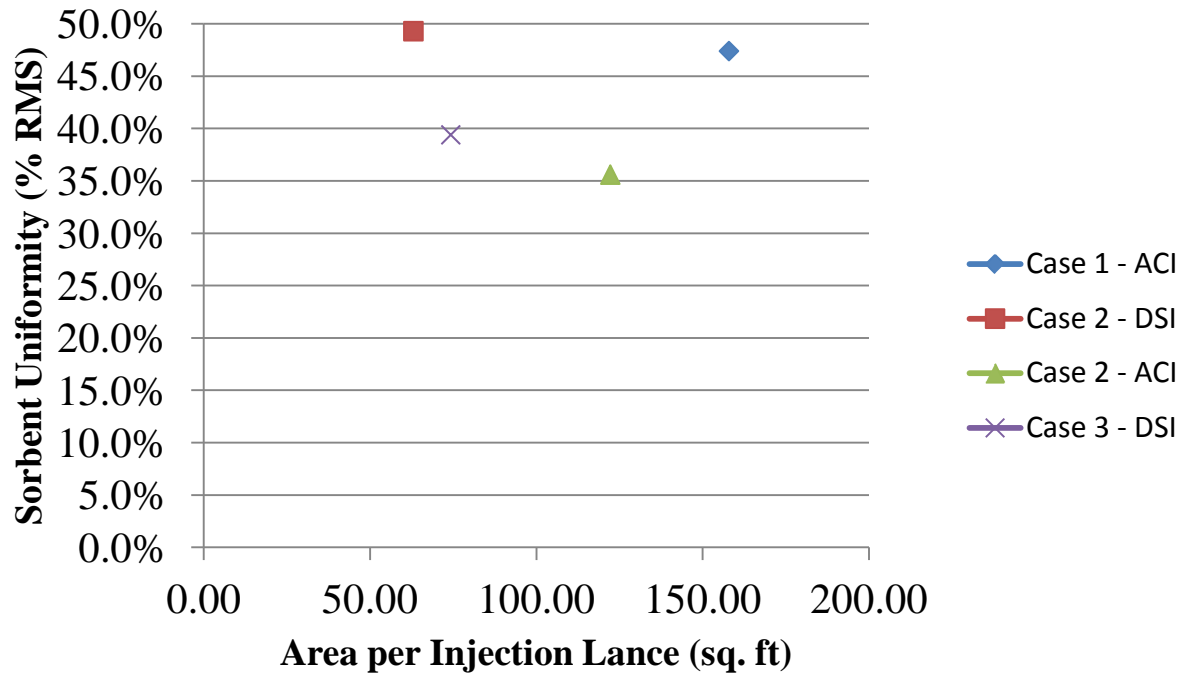

# Future Considerations

## ❖ More Lances = Better Uniformity

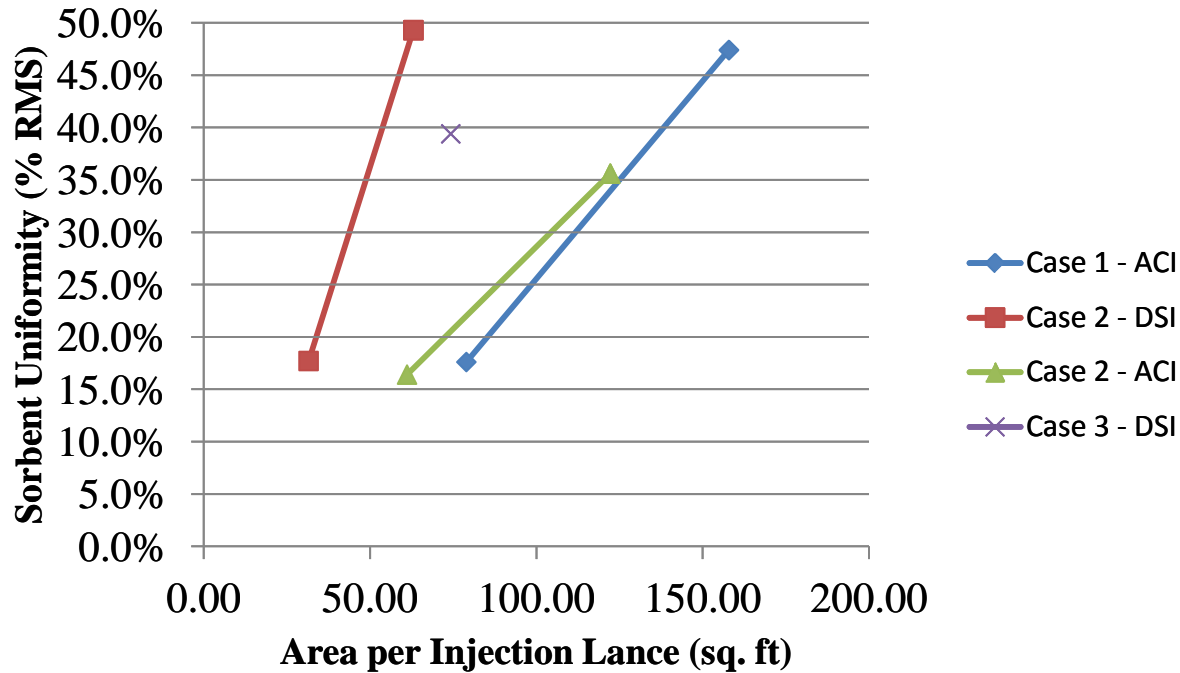

Cases 1 and 2, the number of lances had to be doubled to approach the uniformity goals.

# Future Considerations

## ❖ More Lances = Better Uniformity

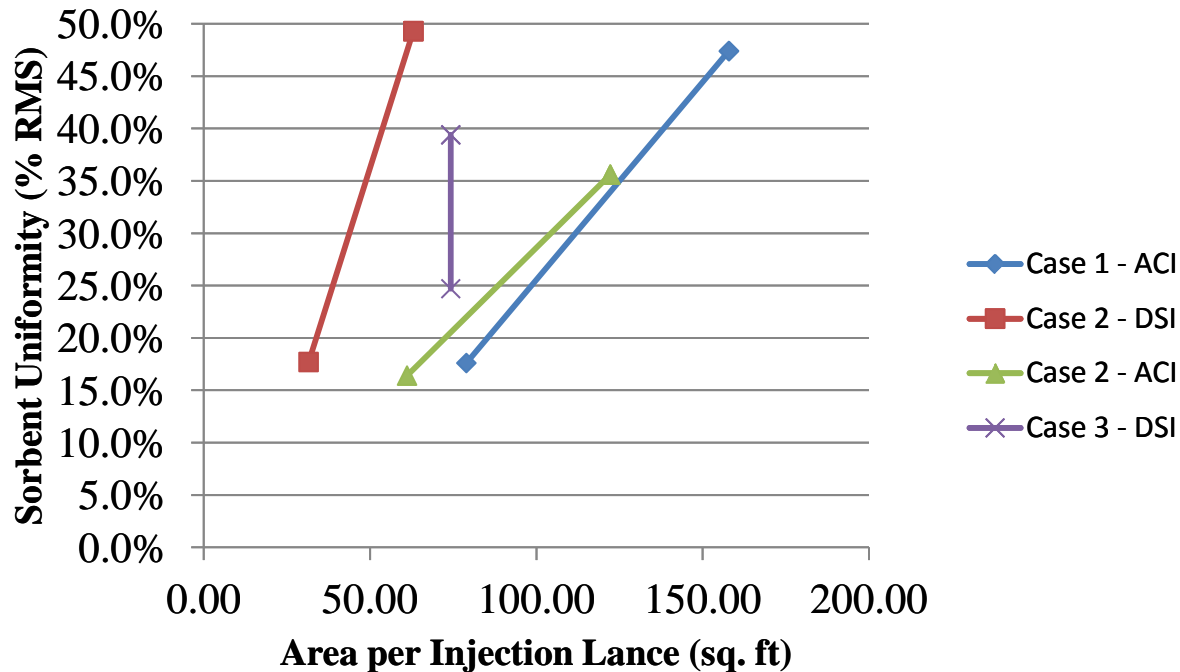

Cases 1 and 2, the number of lances had to be doubled to approach the uniformity goals.

The lance configuration was fixed for Case 3, but the addition of a low dp static mixer proved effective at significantly improving the uniformity.

# Future Considerations

- ❖ Is your lance configuration well-suited for the duct aspect ratio?

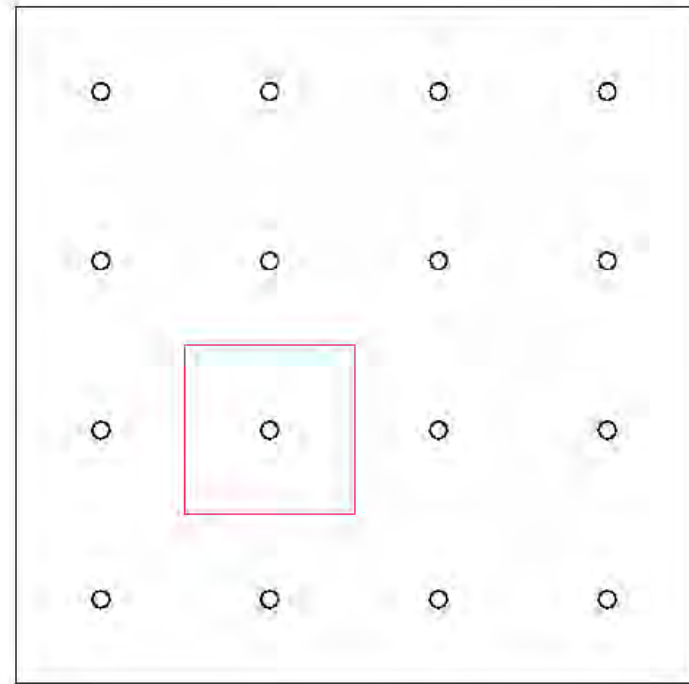
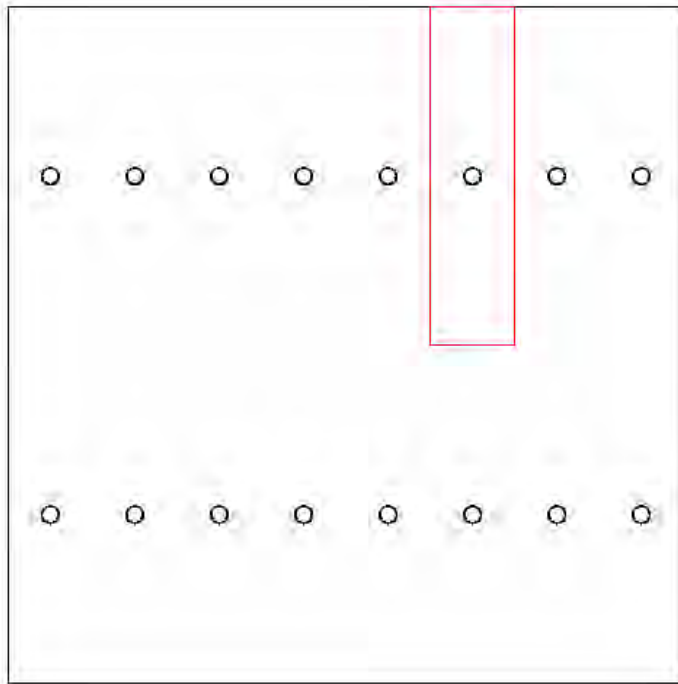

Preferred Orientation

# Future Considerations

- ❖ Is your lance configuration well-suited for the duct aspect ratio?

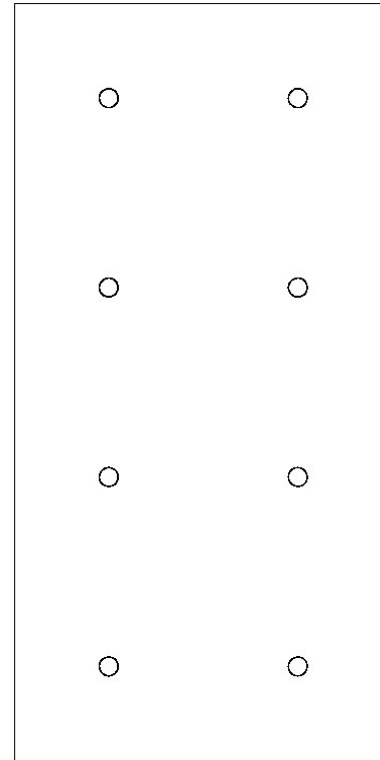
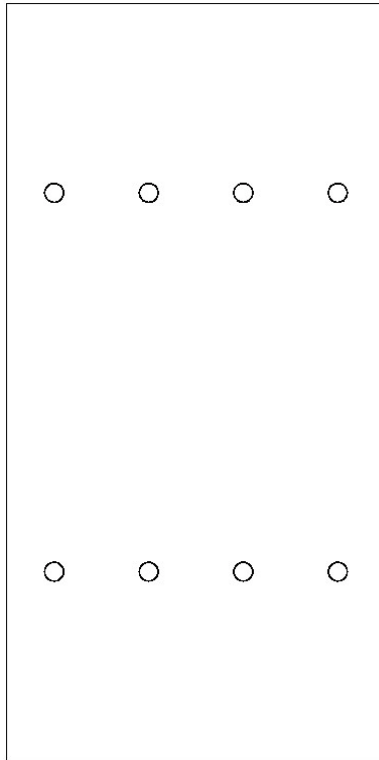

Preferred Orientation

# Future Considerations

- ❖ Mixer?
- ❖ Pressure loss limitations
- ❖ Local or global mixing?
- ❖ Truss location and design

# Future Considerations

## ❖ Modeling vs. Real-Life

- 15%-20% RMS is the industry standard for “uniform” distribution
- RMS required may depend on what is downstream  
FF > WFGD > ESP
- How does this compare to actual system effectiveness, “Will I meet my guarantee?”
- A database of correlation data could be developed based on the many projects that have already been completed in order to give modelers, injection companies, and end users confidence regarding the system performance.

# Conclusions

- ❖ Fluid dynamics and thermodynamics have significant impact on the performance of power plant equipment
- ❖ CFD/Physical modeling is used to optimize the position and arrangement of sorbent injection lances

Better uniformity  Less sorbent usage  Reduced operating cost

# Questions?

Matt Gentry

734-525-0300

[mgentry@airflowsciences.com](mailto:mgentry@airflowsciences.com)

